

MODEL 26A STANDARD SERIAL No. _____

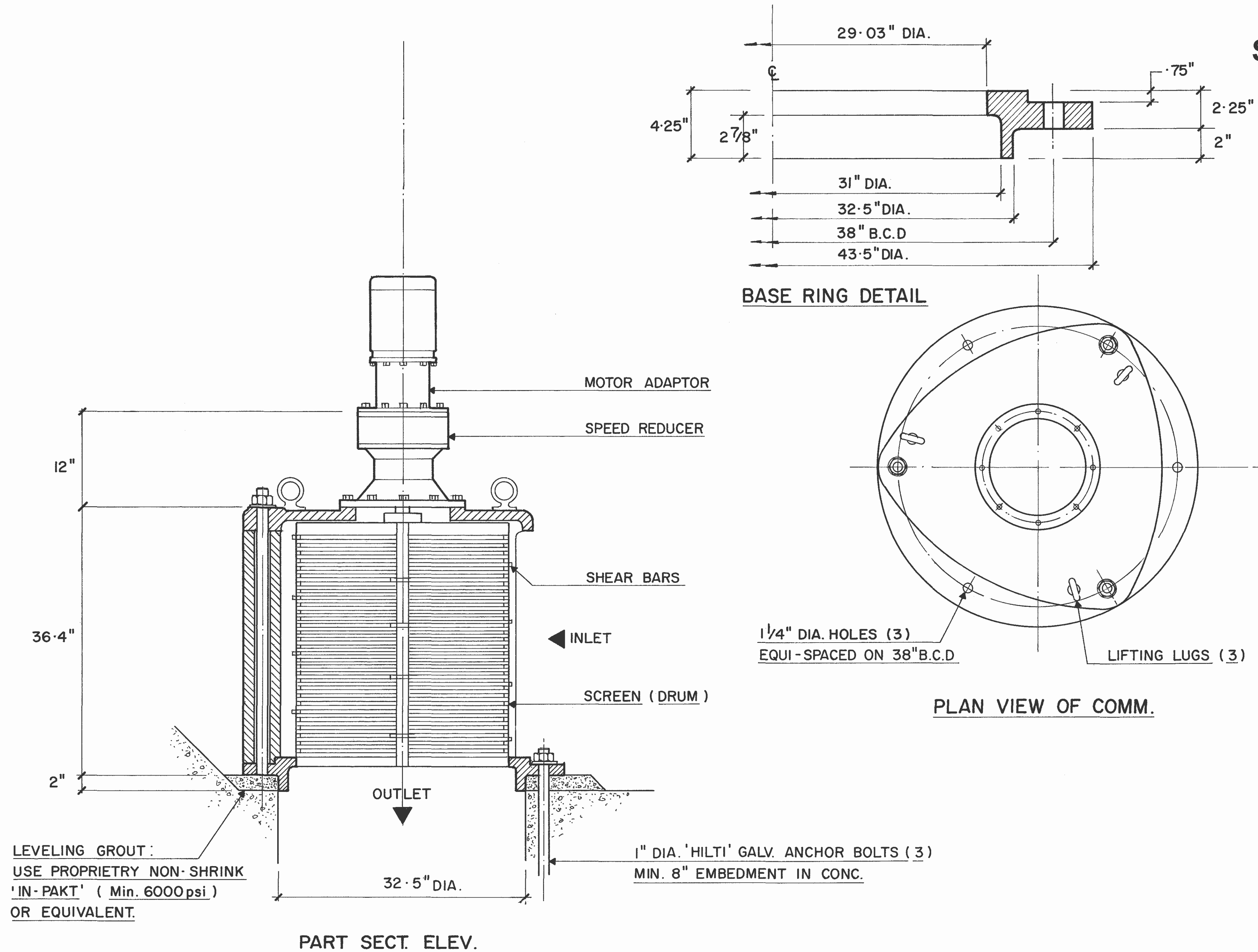

MATERIALS OF CONSTRUCTION & GENERAL ENGINEERING DATA

HOUSING:	GREY IRON	CAPACITY:	20 MGD (US)/75700 m ³ /day	INLET AREA:	1076 sq in 6942 cm sq
DRUM (SCREEN):	DUCTILE IRON (ASTM 536 GRADE 60-45-18)	DRUM SPEED:	30 RPM	OUTLET AREA:	537 sq in 3465 cm sq
SHEAR BARS:	AISI-A2 HIGH ALLOY TOOL STEEL	ROTATION:	CLOCKWISE	DRUM DIAMETER:	29 in 737 cm
CUTTING BARS:	AISI-01 TOOL STEEL REVERSIBLE	SLOT WIDTH:	0.470 in / 12 mm	WEIGHT:	2500 lb 1136 kg
HARDWARE & FASTENERS:	304 STAINLESS STEEL	NO OF SLOTS:	116		
MOTOR MANUFACTURER:		POWER:	/ /	RPM:	1750
STYLE: TEFC (IP55)	HP: 3	KW: 2.24	FRAME: 182TC	FLANGE: 'C'	SM-CYCLO REDUCER MODEL: V6170
				RATIO: 59:1	RATING: 16.1 HP

REVISIONS	BY	DATE	APP.
G.E.T. INDUSTRIES INC.			
(877) 213-7418			
www.grindhog.com			
TOLERANCES			SCALE
±			NTS
DECIMAL			DRAWN BY
±			APPROVED BY
FRACTIONAL			WDM
ANGULAR			
±			
DATE	PROJECT NO.	DRAWING NO.	REV.
		6 0290	

Grind Hog MODEL 26A (CAPACITY: 20 USMGD)

REPLACEMENT OF CHICAGO PUMP MODEL 25A

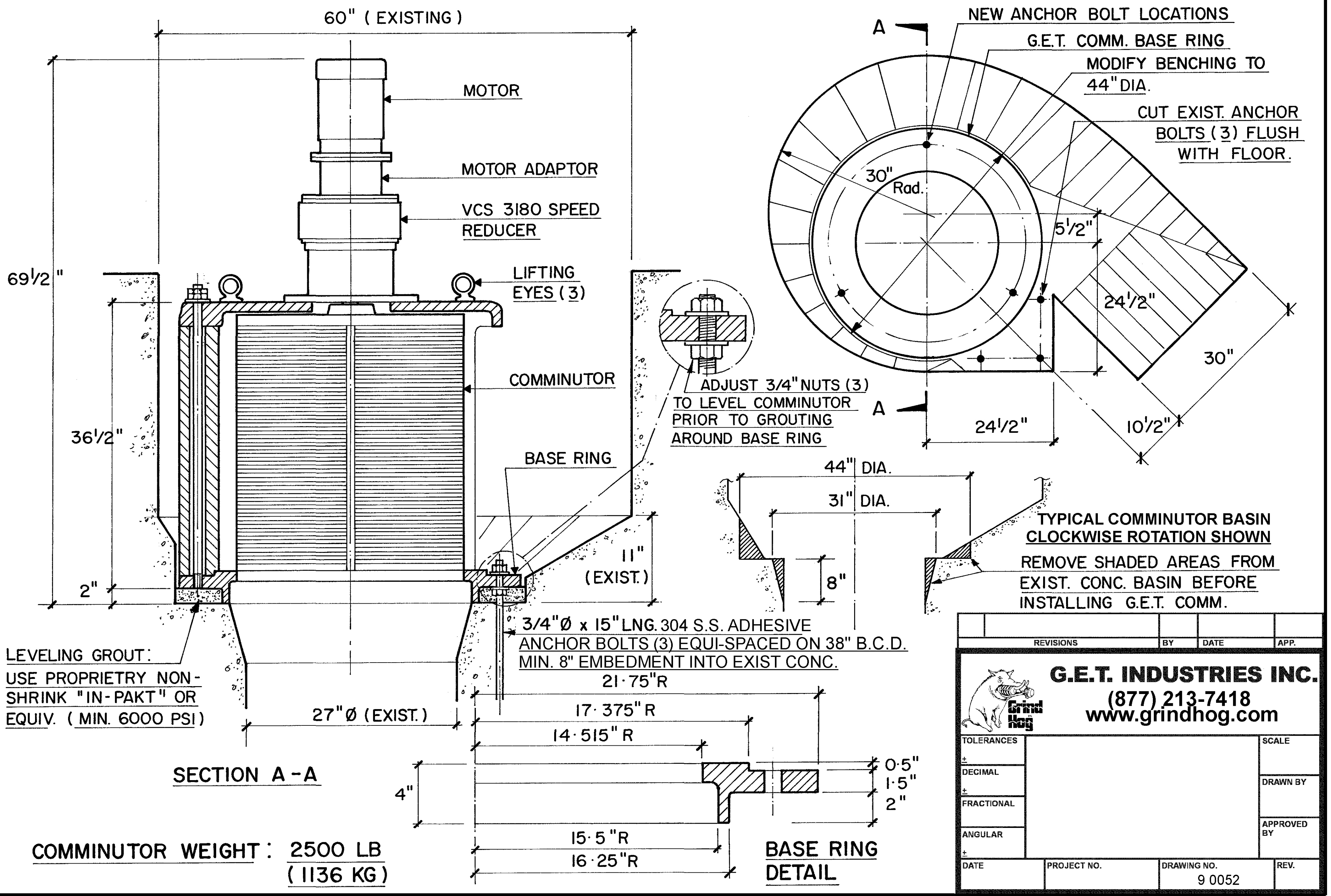

LEVELING GROUT:
USE PROPRIETARY NON-SHRINK "IN-PAKT" OR EQUIV. (MIN. 6000 PSI)

REVISIONS		BY	DATE	APP.
 G.E.T. INDUSTRIES INC. (877) 213-7418 www.grindhog.com				
TOLERANCES				SCALE
± DECIMAL				DRAWN BY
± FRACTIONAL				APPROVED BY
ANGULAR				
DATE	PROJECT NO.	DRAWING NO.	REV.	
		9 0052		

Grind Hog MODEL 26A (CAPACITY: 20 USMGD)

REPLACEMENT OF CHICAGO PUMP MODEL 36A

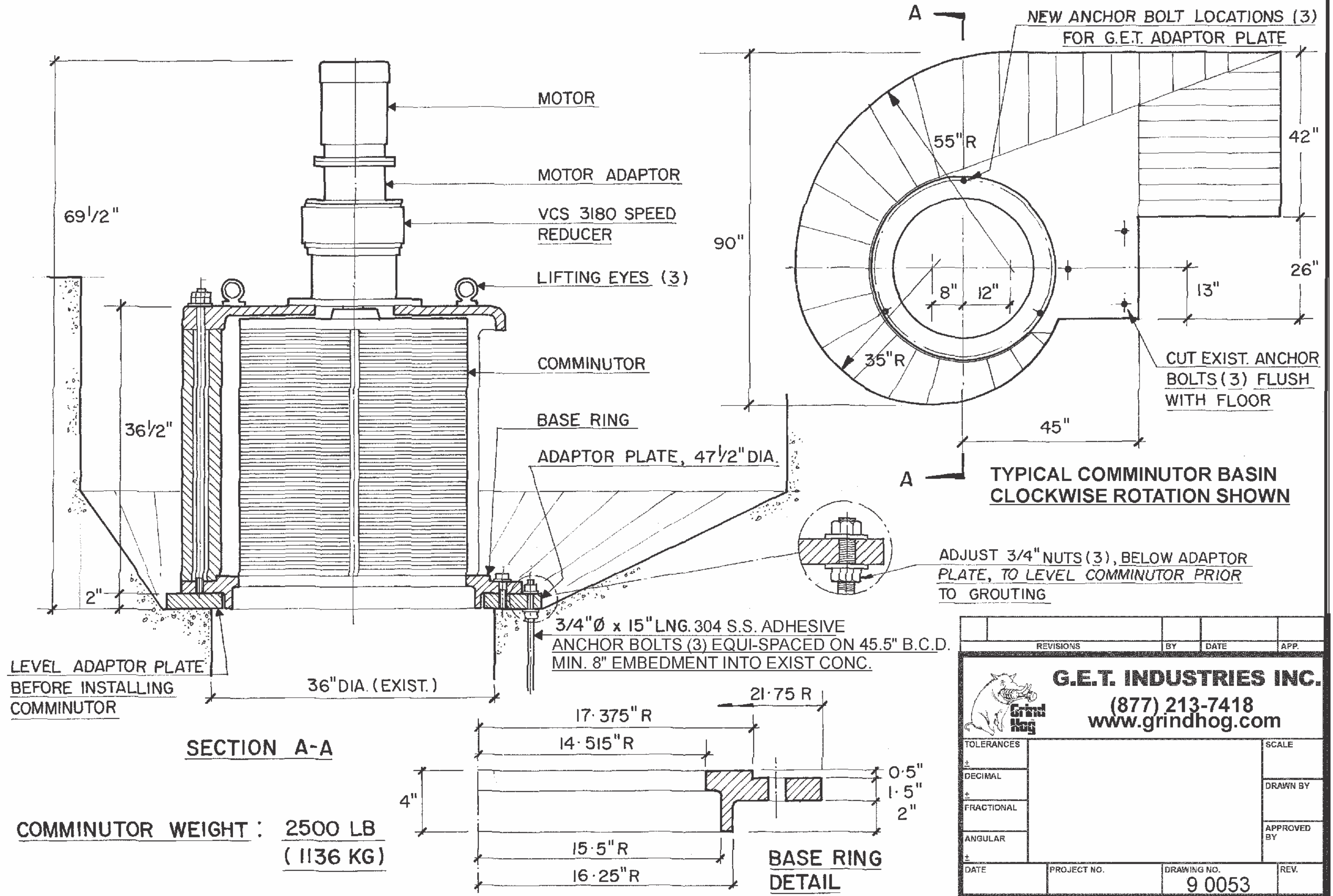

REVISIONS		BY	DATE	APP.
 G.E.T. INDUSTRIES INC. (877) 213-7418 www.grindhog.com				
TOLERANCES				SCALE
±				DRAWN BY
DECIMAL				
FRACTIONAL				
ANGULAR				APPROVED BY
DATE	PROJECT NO.	DRAWING NO.	REV.	
		9 0053		



RETROFITTING CHICAGO PUMP COMMINUTORS



All models... All installation arrangements





CHICAGO PUMP COMMINUTOR Retrofit Questionnaire



- Model of existing unit
- Existing characteristics of power supply
- Drive arrangement - close coupled, support column - elevated drive
- Photos of current installation
- Desired capacity (gpm) of replacement unit
- Dimensional detail of structure.... (i.e. free discharge or controlled discharge)
- Details of existing Control Panel (if any)
- Distance of the high water mark above the basin floor



G.E.T. Industries Inc.

T: 877-213-7418 / www.grindhog.com



**CITY OF COLONIAL HEIGHTS
COLONIAL HEIGHTS, VIRGINIA**

Grind Hog™ 26ASX

REPLACEMENT OF
CHICAGO PUMP 36A

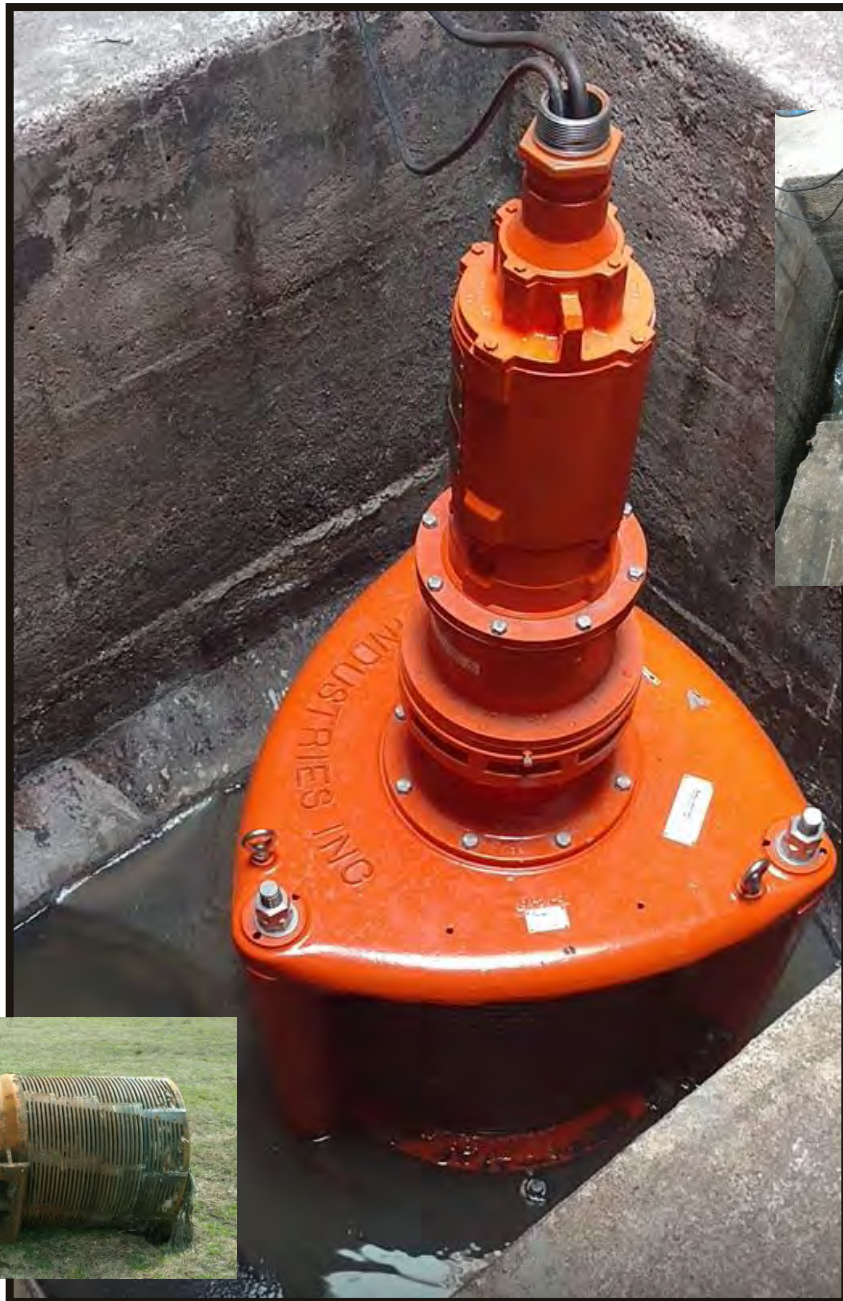



Grind Hog™

BERLIN TURNPIKE PUMP STATION - BERLIN, CT



REPLACEMENT OF CHICAGO PUMP 25A

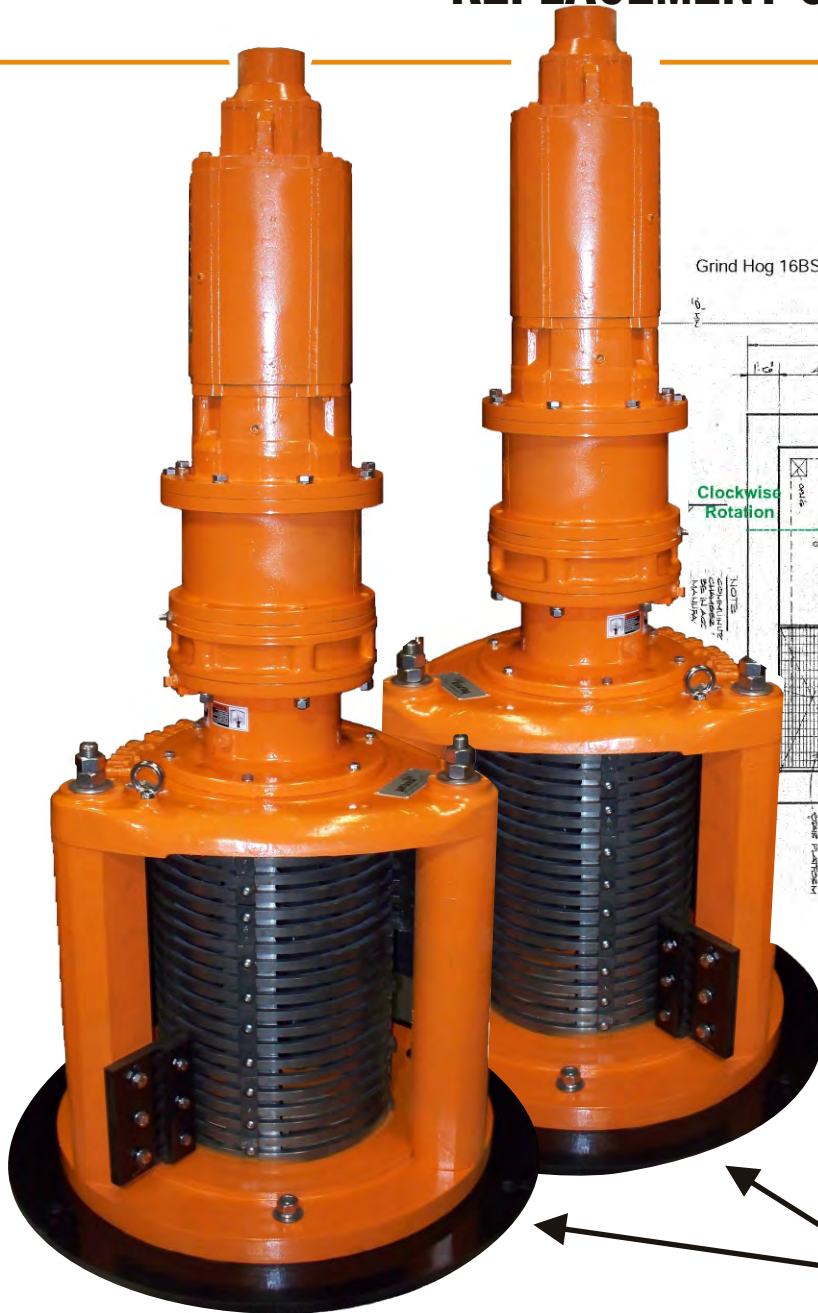

CHICAGO PUMP 25A BASIN DETAIL

Grind Hog 16BSX Ser. 9151 Clockwise Rotation, Ser. 9152 Counter Clockwise Rotation

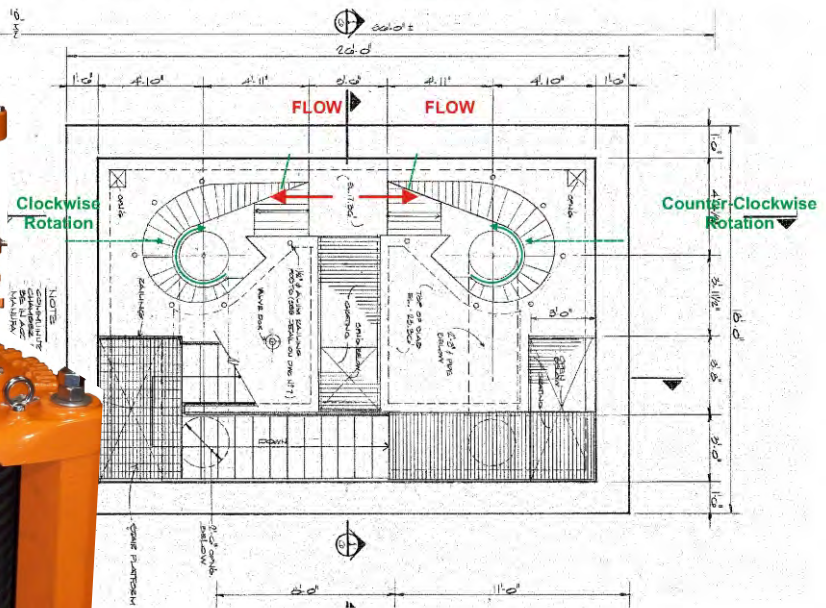

Grind Hog™ 16BSX
One - Clockwise
One - Counter-Clockwise

Mounting Plates
to Suit Existing Basins